

# FIRST TEAM SPORTS, INC

## Olympian Series Assembly Instructions

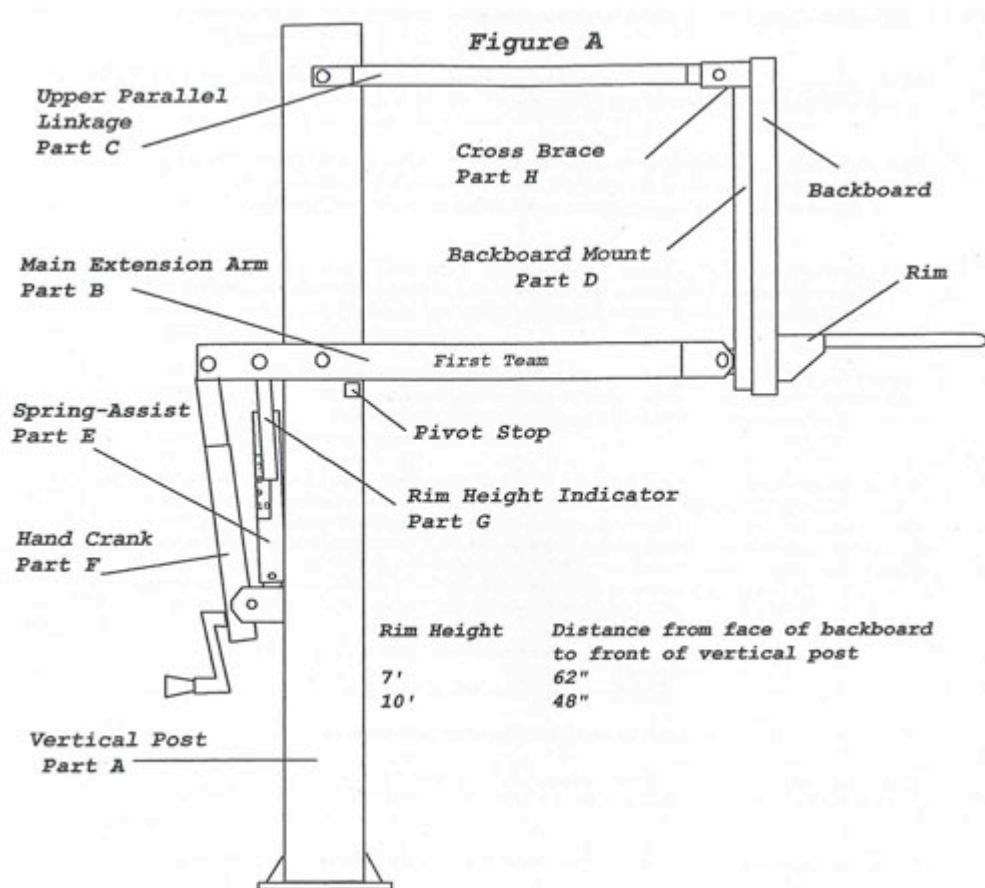

### Bill of Materials

A (1) Vertical Post	K (1) 5/8" x 7" Hex Bolt	U (10) 3/8" Flatwasher
B (1) Main Extension Arm	L (1) 5/8" x 8" Hex Bolt	V (10) 3/8" Lockwasher
C (2) Parallel Linkage	M (4) 5/8" Anchor Bolt	W (10) 3/8" Hex Nut
D (1) H-Frame Backboard Mount	N (4) Anchor Footing Rebar	X (1) Rim Height Sticker
E (2) Spring-Assist Cartridge	O (1) Anchor Footing Template	Y (4) 5/8" Lockwasher
F (1) Crank Adjustment Cylinder	P (3) 5/8" x 12" Hex Bolt	Z (1) Anti-Seize Lubricant
G (1) Rim Height Indicator	Q (1) 5/8" x 13" Hex Bolt	AA (2) Pivot Stop Caps
H (1) Cross Brace	R (9) 5/8" Lock Nut	BB (2) 5/8" Nylon Flatwasher
I (2) 5/8" x 1 1/2" Hex Bolt	S (12) 5/8" Hex Nut	
J (1) 5/8" x 4 1/2" Hex Bolt	T (10) 3/8" 1 1/4" Hex Bolt	

**NOTE: Immediately unpack all components and cross check against bill of materials. Report any shortages to First Team customer service at 1-888-884-6677.**

**1. CAUTION: YOUR SPRING-ASSIST CARTRIDGES ARE SHIPPED UNDER TENSION. DO NOT**

**REMOVE WOODEN SPREADER BLOCKS FROM SPRING-ASSISTS UNTIL INSTRUCTED TO DO SO. FOLLOW INSTRUCTIONS CAREFULLY.**

2. Choose the proper location to dig for the concrete footing. Use the distance chart in figure A to help you make your decision. When choosing the exact position to dig, make sure to maximize the amount of playing surface while minimizing possible driveway obstruction.
3. Dig hole 48" deep and 24" square. Be sure to bell out the bottom 12" of the hole to give added stability to the footing. NOTE: If you live in an area where the frost line is below 48" it is advisable to dig to normal frost line. **Do not cheat on the hole size, it is imperative that the hole be a minimum of 48" deep and 24" square!**
4. Assemble the anchor kit as shown in Figure B. First thread a 5/8" hex nut 2 1/2" of the way on to each J-Bolt. Place the threaded end of each J-Bolt through the 4 holes located in the anchor template. Then thread a second 5/8" nut on to each J-Bolt until tight against the template, making sure to keep the J-Bolt hooks pointing in toward the center of the template.
5. For this step you will need: Level; Broomstick; Tape Measure. The 48" x 24" anchor footing will require a little over a 1/2 yard of 3000 psi concrete (32-34 60# sacks of premix concrete). More will be needed if you dig a larger hole. Make certain that you have enough concrete to finish the job. Allowing a portion to dry while you purchase more concrete will weaken the footing.
6. Mix the concrete according to the instructions on the bag. It is better to mix it slightly wet than too dry. Fill the hole full to ground level with as little time between batches as possible. Insert the broomstick in 3 or 4 different places and vibrate up and down to settle the concrete. Submerge the (4) anchor footing rebar pieces into the center of the hole spaced evenly. Next set the anchor bolt assembly into the wet concrete, vibrate it as it goes in to make sure the concrete fills in around the J-Bolt hooks. Make sure the template is pressed firmly against the top of the wet concrete. Use the level to ensure that it is level in all directions. Additionally, the center line of the J-Bolts must be parallel with the edge of the playing surface. (See figure C)

**STOP HERE! Allow footing to cure for seven days before proceeding.**

7. Take off the top 5/8" nuts from the J-Bolts, remove the template and discard it.
8. Thread a second 5/8" nut on to each J-Bolt down against the nut embedded in the concrete.
9. Place the vertical post (A) down over the footing making sure not to damage the J-Bolt threads. Using (4) 5/8" lockwashers and the final (4) 5/8" hex nuts, bolt down post finger tight with welded tabs facing away from playing surface.
10. Level the vertical post by adjusting the 5/8" nuts located underneath the base plate. Then tighten top nuts against the top side of the base plate.
11. Attach both pivot stop caps (AA) over the ends of the square blocks (pivot stops) welded near the upper end of the post.

**IMPORTANT!!! IMPORTANT!!! IMPORTANT!!!  
FROM THIS POINT FORWARD DURING ASSEMBLY, BE SURE TO SPREAD A GENEROUS LAYER OF  
ANTI-SEIZE LUBRICANT OVER THE ENTIRE SHAFT OF EACH 5/8" HEX BOLT. THIS LUBRICANT  
WILL GUARD AGAINST RUST, AND HELP ENSURE PROPER PIVOT OPERATION IN YEARS TO  
COME.**

NOTICE: Anti-Seize lubricant is EXTREMELY MESSY. An old toothbrush, etc. may be used to smear lubricant onto bolts instead of using your finger. Have clean up rags available.

12. Slide the main arm (B) over the top of the vertical post and attach to the lower pivot tube with a 5/8" x 12" hex bolt and a 5/8" locknut. **Be sure to smear lubricant on bolt shaft!!!**

13. Next attach the hand crank adjustment cylinder using a 5/8" x 12" hex bolt and 5/8" x 4 1/2" hex bolt. Tighten each with a 5/8" locknut. **Be sure to smear lubricant on bolt shaft!!!**

14. Line up the hole located in the rim height indicator (rim height indicator is black plastic w/hole in one end) over the hole in one of the second set of welded tubes in the main arm. Attach both spring-assist cartridges to the main extension arm using a 5/8"x 12" hex bolt and 5/8" hex nut. In order to attach both cartridges, lower the open end of each spring-assist cartridge down over the top of each welded tab as shown in Figure A. Use the 5/8" x 7" hex bolt & 5/8" locknut to attach them to the welded tabs. The rim height indicator should hang freely along the outside of one of the cartridges. Next, remove and discard the wooden spreader block from each spring-assist cartridge. **Be sure to smear lubricant on bolt shafts!!!**

15. Attach parallel linkages (C) to vertical post with 5/8" x 8" hex bolt and a 5/8" locknut. Attention: It does not matter which end of the parallel link you attach to the vertical post. **Be sure to smear lubricant on bolt shaft!!!**

16. Unpackage and lay your backboard face down on your working surface. If you have a tempered glass or acrylic backboard check to make sure all four steel grommets are located at the rim holes, if any are missing check in the box (if grommets are missing and cannot be located do not proceed with installation, call First Team immediately). Additionally, if you purchased an acrylic backboard you will find two black rubber gaskets packaged with your backboard. Disregard the gaskets, you will not need them.

17. Lay the Cross Brace (H) down into backboard aligning the 6 holes in the Cross Brace with the 6 holes in the top of the backboard (welded tabs should face backward away from the backboard).

18. Next, lay the H-Frame down into backboard aligning the four top and bottom holes in the H-Frame with the four holes in the top and bottom of the backboard. Check to make sure the rim hole pattern in the H-Frame lines up with the rim hole pattern in the backboard, adjust as needed. When you are satisfied with alignment, attach backboard to H-Frame and Cross Brace at all points along the top and bottom of the board using the 3/8" x 1 1/4" hex bolts, flatwashers, lockwashers and hex nuts as shown in Figure D. Tighten all 3/8" hardware.

19. Mount the Cross Brace/H-Frame/Backboard assembly lower pivot tube first to the main arm using (1) 5/8" x 13" hex bolt and (1) 5/8" locknut. Next, attach the Cross Brace Tabs to the upper parallel linkages using (2) 5/8" x 1 1/2" hex bolts, 5/8" Nylon Flatwasher and (1) 5/8" locknut. **NOTE: THE 5/8" NYLON FLATWASHERS PROVIDED SHOULD BE SANDWICHED BETWEEN THE CROSS-BRACE AND THE UPPER LINK TO AVOID METAL-TO-METAL CONTACT WHICH CAN CAUSE THE PAINT TO RUB OFF!!!**

20. Check face of backboard to see if it is level forward and back. If it is out of level, correct it by adjusting the 5/8" nuts located underneath the vertical post base plate.

21. Mount the rim to the Cross Brace/H-Frame/Backboard assembly using the hardware supplied in the rim box. Use a level to make sure rim is level side to side before tightening nuts.

22. After everything is square, make sure all nuts have been tightened. However, do not overtighten, if unit is excessively difficult to crank up and down the main pivot nuts are probably too tight.

23. To apply the rim height sticker, first use a tape measure to crank rim up to exactly 10' from the playing surface. Use a pencil to make a mark on the spring-assist outer tube where the bottom of the rim height indicator stops. Then, peel and apply sticker to outside of spring-assist cartridge lining up the pencil mark with the 10' mark on the sticker. See Figure A for a diagram of a completed height indicator assembly.

**Note: It is advisable to wait up to two weeks to allow the anchor footing to fully cure before aggressive play.**

*Figure B*

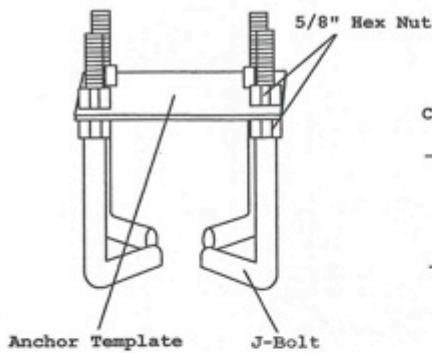

*Figure C*

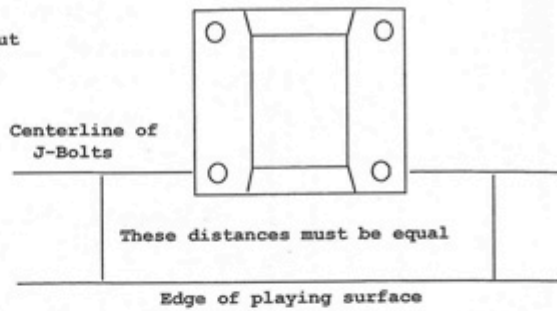

*Figure D*

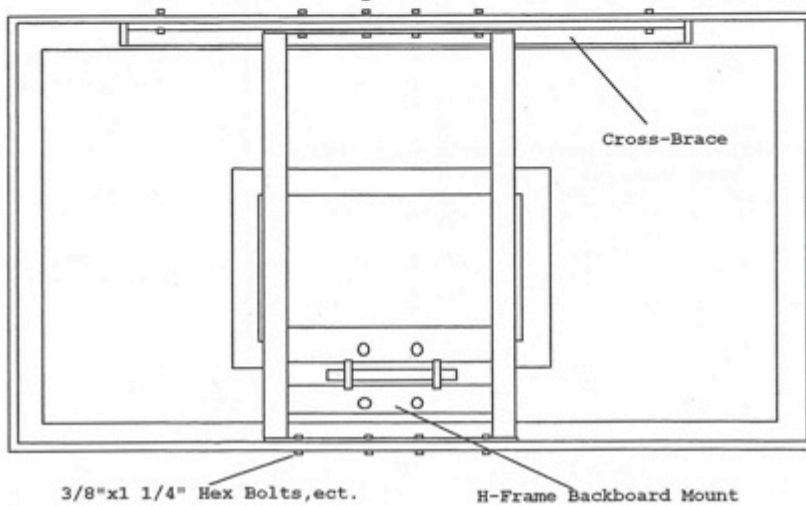

**FIRST TEAM SPORTS, INC.  
902 COREY ROAD  
HUTCHINSON, KS 67501  
TOLL FREE: 888-884-6677**